

Senior Design Project Proposal

Flow Control “Needle” Assembly Machine

Background

“Needle Assemblies” are flowrate control (throttling) devices typically integrated into speed control and end-of-stroke shock absorbing systems used in pneumatic actuating cylinders where they control the bleed rate of compressed fluid from a closed cavity. Needle assemblies are characterized by a tapered “needle” threaded into a “needle retainer” with a suitable annular seal retained in a mating groove within the body of the needle. Historically, needles have been manually threaded into mating retainers and seals have been manually placed onto needles. It is very desirable to automate this repetitive assembly process.

The rendering below shows typical locations for needle assemblies on a pneumatic cylinder.

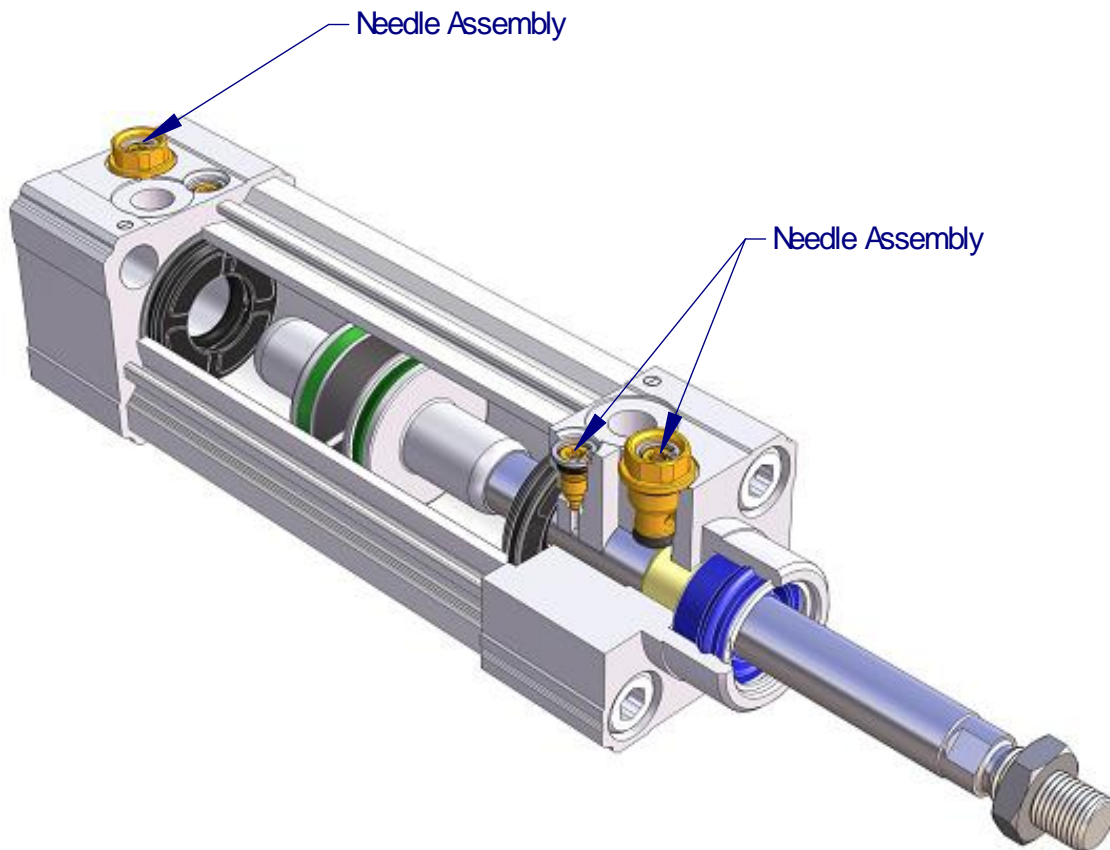

The figure below illustrates a typical needle assembly consisting of retainer, needle, and seal.

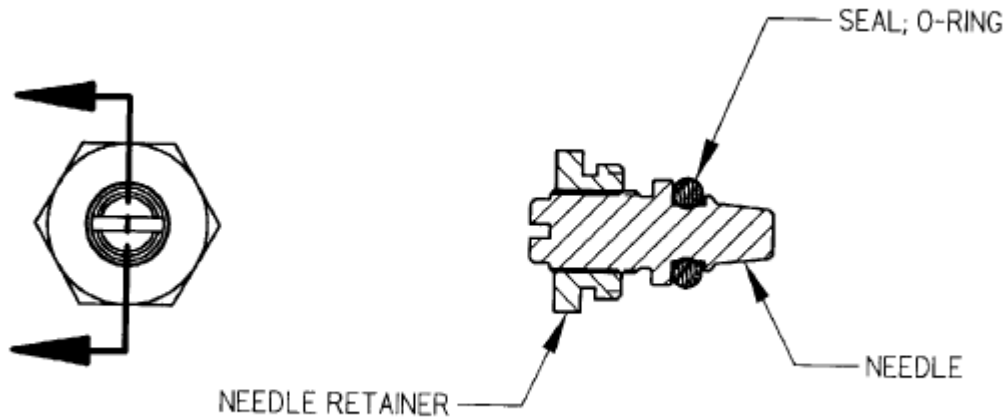

Project Scope

Develop a machine capable of producing needle assemblies. The machine will operate with minimal human attention and intervention. Ideally, the human operator will only load the part hoppers and remove the finished assemblies from the machine. **The machine will be equipped with an emergency stop (E-stop) button that will immediately and safely stop all machine functions when depressed.** The machine will accept randomly oriented parts from a suitable conveyer system (e.g. vibratory bowl feeder, hopper, magazine), properly orient the parts with respect to one another, thread the needle into the retainer to a specified depth, and apply a seal into the mating seal groove of the needle. The machine will deliver the completed assemblies into a suitable container in a manner that does not damage the assembly. The machine will keep a resettable, running numerical count of the assemblies produced. A minimum run rate of one assembly produced every second will be supported by the machine. The machine will be designed as a single station, with the understanding that production can be increased by adding additional like stations. Motive power for the machine can be electric and / or pneumatic.

It is desired that the machine incorporate suitable methods of piece-part conveyance (e.g. a vibratory bowl feeder, gravity feed hopper, etc.), but if including such conveyance elements consumes a disproportionate portion of the total budget, they can be simulated for the purpose of the project. For example, if a vibratory bowl feeder will be used to convey parts to an infeed track for part orientation prior to assembly, it is acceptable for purposes of the project to simulate the action of the bowl feeder by manually placing randomly oriented parts into a magazine attached to the track and pushing the parts onto the track as the machine is being run.

Detailed dimensional drawings of the retainer / needle / seal combinations to be assembled will be provided under separate cover.

Project Budget

A budget of at least \$2000 is allocated for the purchase of materials to support the project. PHD, Inc. will make available for loan for the duration of the project, sample piece-parts and completed assemblies for use by the project team. Other components (e.g. motors, pneumatic actuators, etc.) may also be available for loan.